

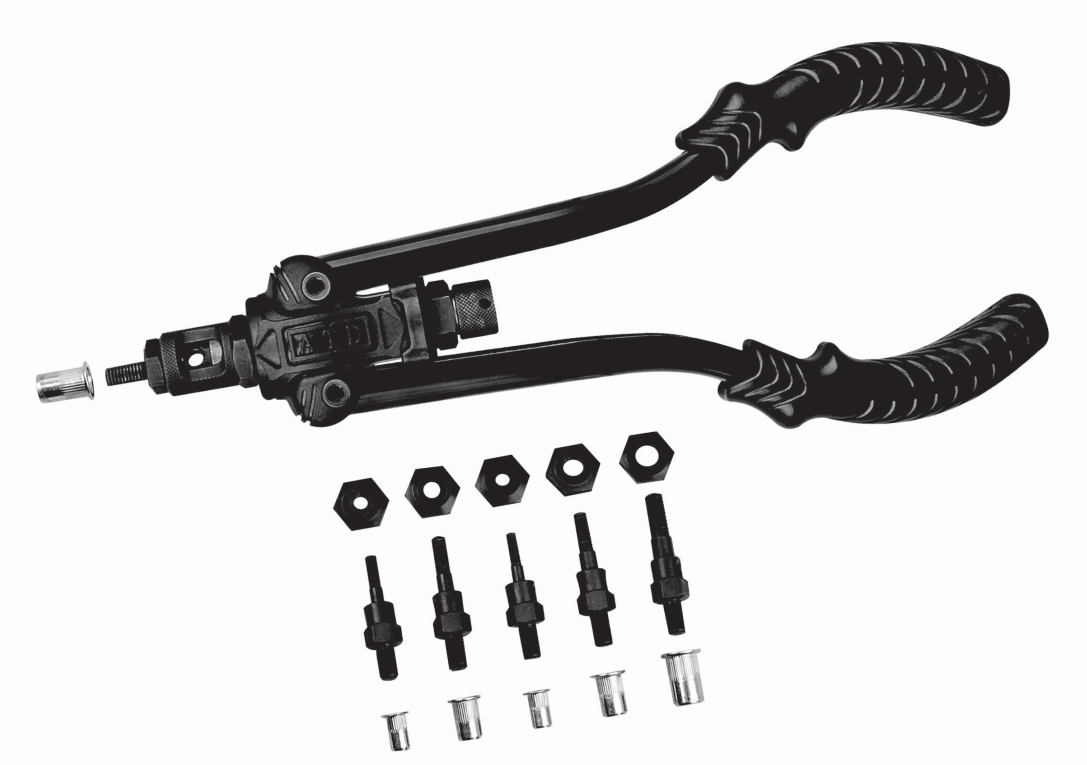

## ATD-5845 12" Nut/Thread Hand Riveter Kit



### Features:

- Perfect for many automotive, electronic or industrial applications
- Use wherever load bearing threads are required in thin materials
- Fast, reliable and low cost method of adding threads without surface damage
- Quick and easy mandrel and nose piece changes

### Set Includes:

- 12" Heavy-Duty Nut/Thread Rivet Tool with double compound hinges for maximum leverage and smooth operation
- (1 each) Metric Mandrel/Nosepiece: M5, M6 and M8
- (1 each) SAE Mandrel/Nosepiece: 10-24, 1/4"-20 and 5/16"-18
- (10 each) Rivet Nuts: M5, M6, M8, 10-24, 1/4"-20 and 5/16"-18
- Wrench

### Available Accessories:

- 150 pc. Rivet Nut Assortment (ATD-337)

## Safety Instructions

1. Read all instructions before using this unit.
2. Always wear ANSI approved safety goggles when using this product.
3. Always wear appropriate safety equipment and clothing when using this product.

## Operating instructions

1. Opening the handles will allow you to screw the rivet nut onto the mandrel. (Figure 1)



2. Insert the rivet nut into the pre-drilled hole in your workpiece after screwing the rivet nut to the mandrel. (Figure 2)

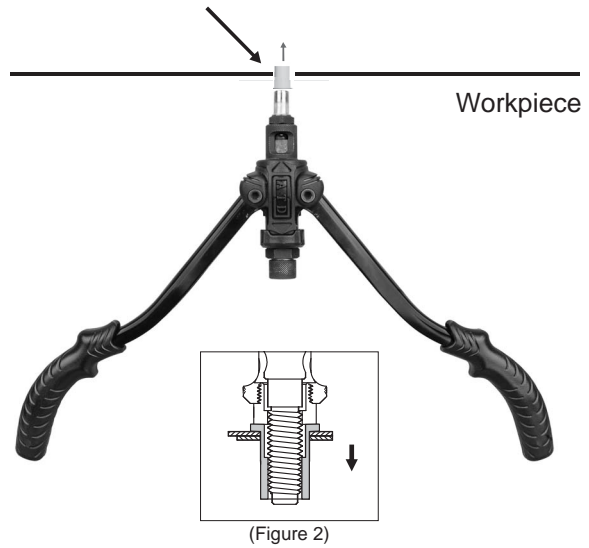

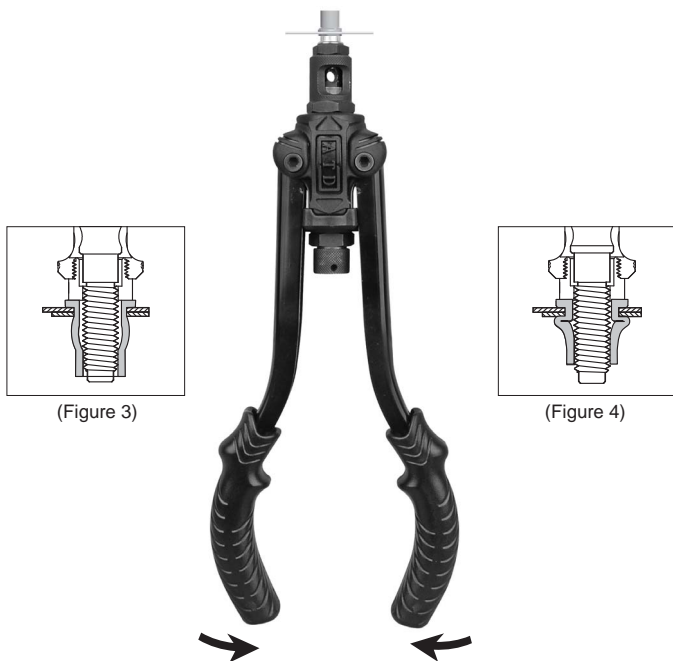

3. After rivet nut is inserted into the rivet hole, close the handles, riveting the nut into position. Quit closing handles when rivet nut is firmly in place. (Figures 3 and 4)

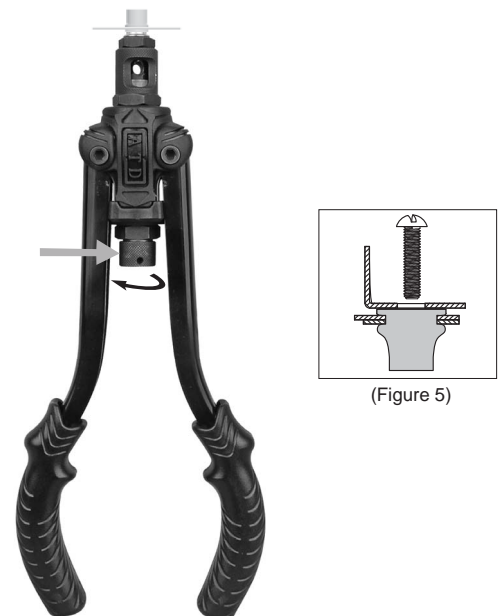

4. After the rivet nut is riveted into place, turn the rotary knob counter-clockwise to unload the rivet nut. The work is fastened, and you can now screw into your riveted nut. (Figure 5)

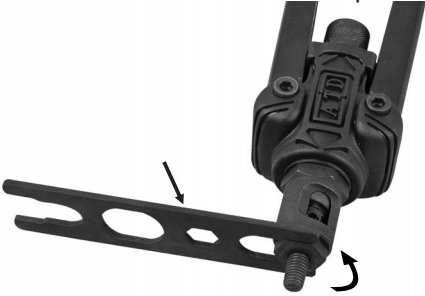
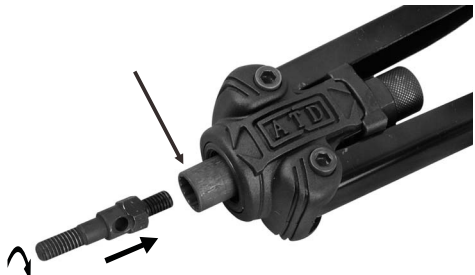
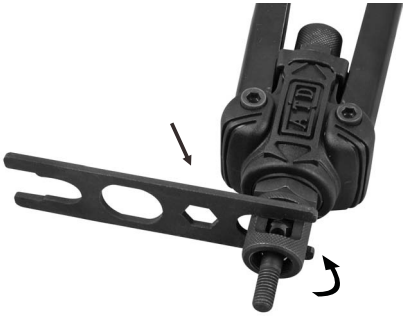

## Replacing the Mandrel

<p>1. Use the wrench to loosen the nosepiece.</p> 	<p>4. Choose correct mandrel and press the sheath, screw mandrel clockwise until tight, then release the sheath.</p> 
<p>2. Use the wrench to loosen and remove sleeve.</p> 	<p>5. Screw and tighten sleeve and corresponding nosepiece back on.</p> 
<p>3. Press the sheath, pull and turn mandrel counterclockwise and remove mandrel</p> 	

## Troubleshooting

Note: If the riveting process isn't done correctly, the riveter won't be easily extracted from the workpiece. If you pull the riveter forcefully, you will damage the unit or the workpiece.

Corrective action: Insert hex key or similar tool (< 5mm) into the lock hole as shown in Figure 1, rotate rotary knob and then the riveter can be released from the workpiece as shown in Figure 2.

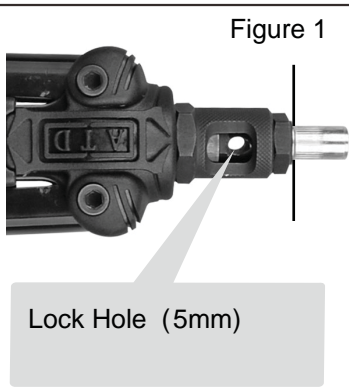
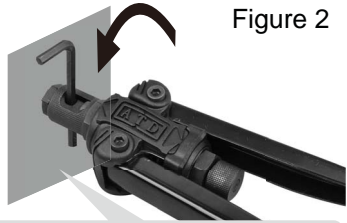
<p>Figure 1</p>  <p>Lock Hole (5mm)</p>	<p>Figure 2</p>  <p>You can choose other similar tools as long as they can be inserted into hole.</p>
--	--

# The Multifunction Wrench

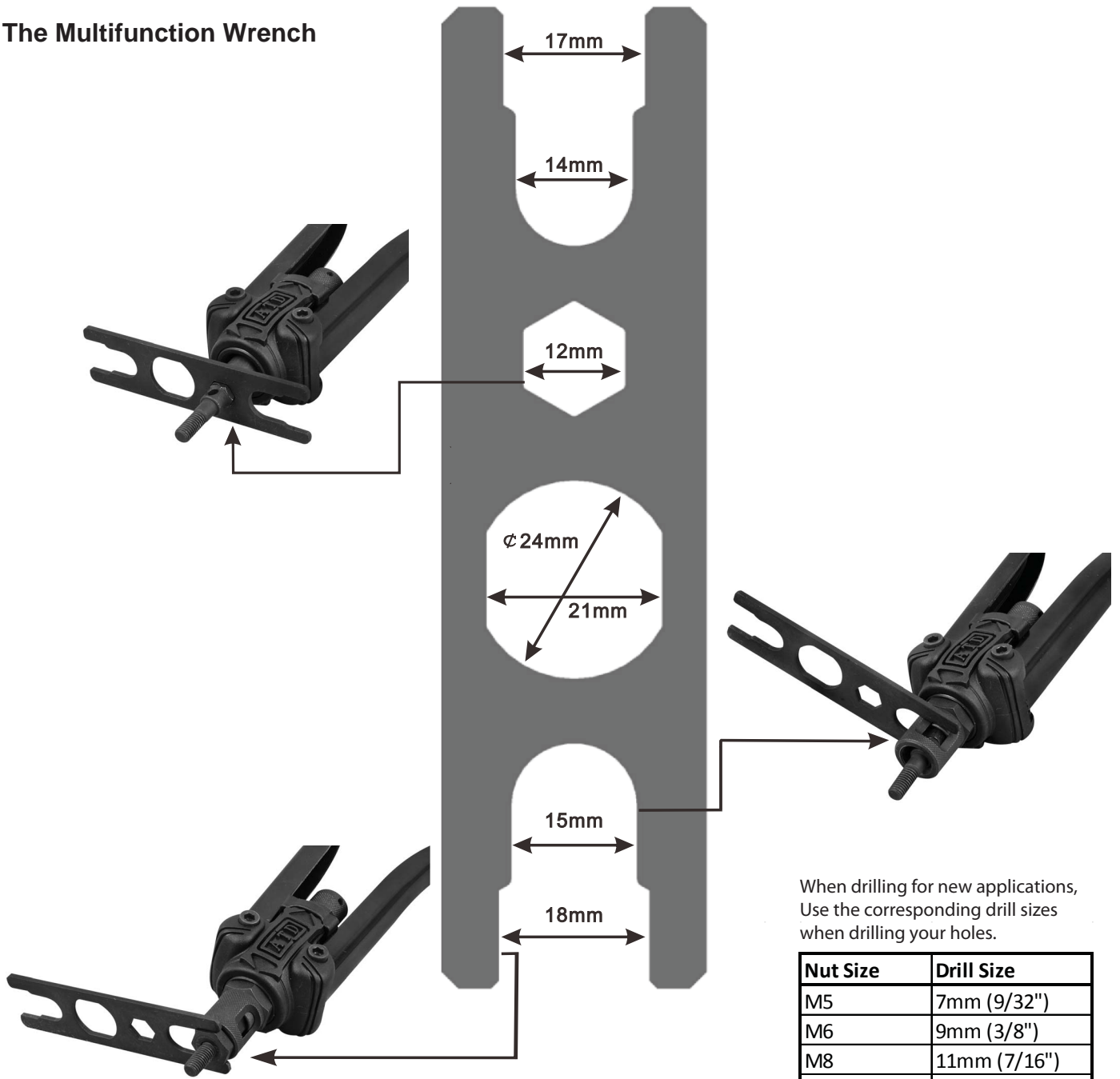

When drilling for new applications, Use the corresponding drill sizes when drilling your holes.

Nut Size	Drill Size
M5	7mm (9/32")
M6	9mm (3/8")
M8	11mm (7/16")
10-24	7mm (9/32")
1/4"-20	10mm (13/32")
5/16"-18	11mm (7/16")

## Riveting nut graph:

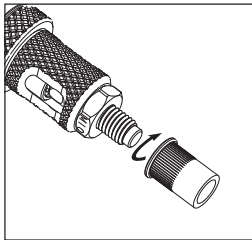

1. Thread rivet nut onto mandrel

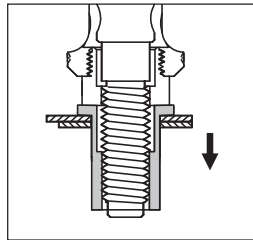

2. Place nut in pre-drilled hole. See chart above for drill size needed for new applications.

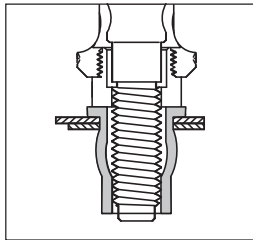

3. The nut is riveted in place

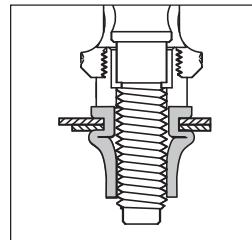

4. Quit when finished riveting

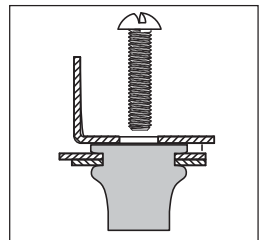

5. The work is fastened



# ATD-5845

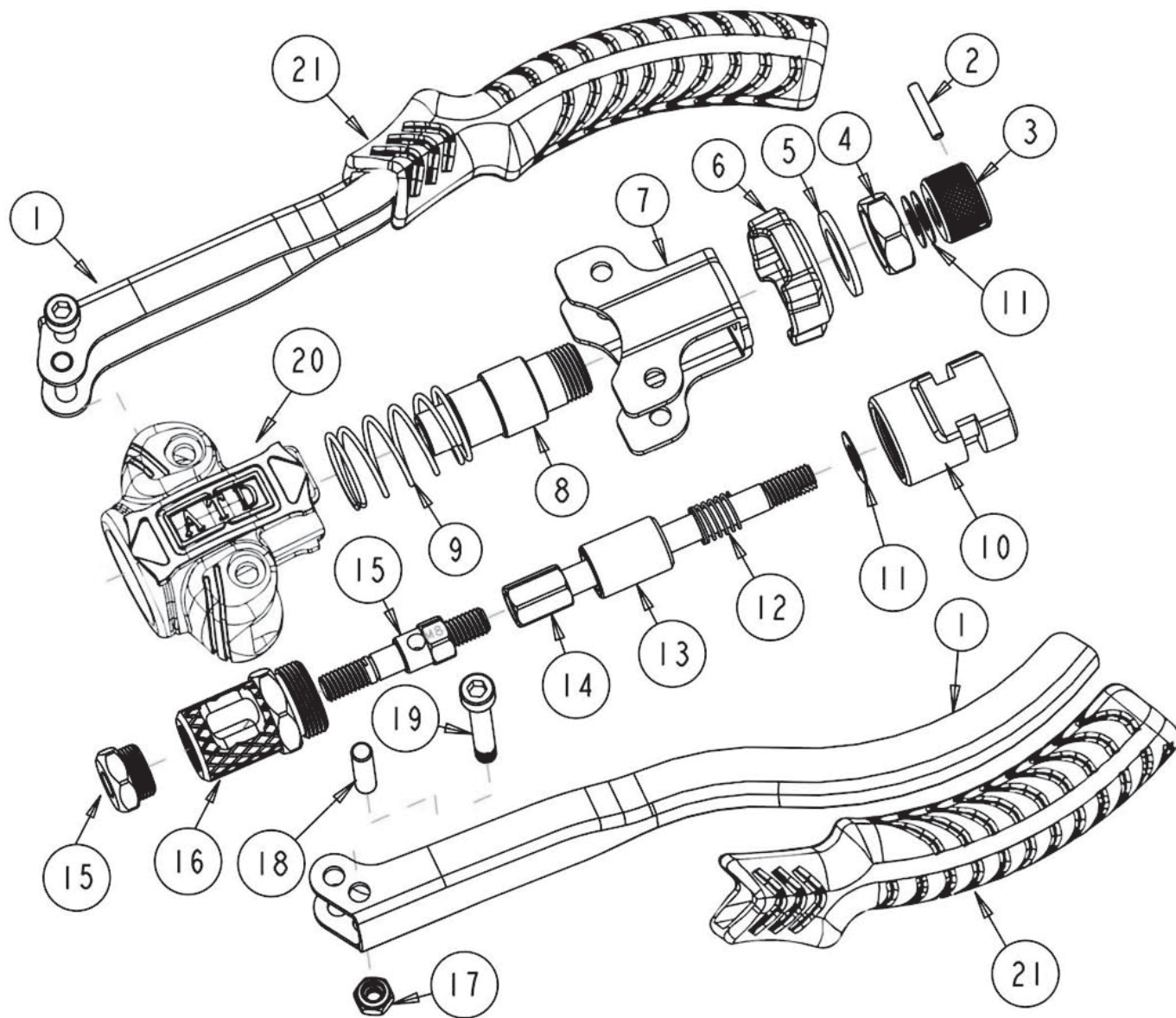

ITEM#	ORDERING PART#	PART DESCRIPTION
1	PRT5845-01	HANDLE (2PCS)
2	PRT5845-02	COTTER PIN
3	PRT5845-03	KNURLED NUT
4	PRT5845-04	BIG NUT
5	PRT5845-05	BIG WASHER
6	PRT5845-06	TOP COVER
7	PRT5845-07	U-SEAT
8	PRT5845-08	BIG FIXED SLEEVE
9	PRT5845-09	BIG SPRING
10	PRT5845-10	SLIDING SEAT
11	PRT5845-11	SMALL WASHER (3PCS)
12	PRT5845-12	SMALL SPRING
13	PRT5845-13	SMALL FIXED SLEEVE

ITEM#	ORDERING PART#	PART DESCRIPTION
14	PRT5845-14	PULL ROD
15	PRT5845-15-1	M5 MANDREL AND NOSEPIECE SET
15	PRT5845-15-2	M6 MANDREL AND NOSEPIECE SET
15	PRT5845-15-3	M8 MANDREL AND NOSEPIECE SET
15	PRT5845-15-4	10-24 MANDREL AND NOSEPIECE SET
15	PRT5845-15-5	1/4-20 MANDREL AND NOSEPIECE SET
15	PRT5845-15-6	5/16-18 MANDREL AND NOSEPIECE SET
16	PRT5845-16	SLEEVE
17	PRT5845-17	SMALL NUT (2PCS)
18	PRT5845-18	PIN ROD (2PCS)
19	PRT5845-19	SCREW (2PCS)
20	PRT5845-20	PLASTIC BODY
21	PRT5845-21	HANDLE SLEEVE (2PCS)



## WARRANTY

### 1 YEAR LIMITED WARRANTY

**THIS WARRANTY AND CONFIRMED RECEIPT(S) SHOULD BE RETAINED BY THE CUSTOMER AT ALL TIMES**

PURCHASED FROM: \_\_\_\_\_

DATE PURCHASED: \_\_\_\_\_

INVOICE/RECEIPT NUMBER: \_\_\_\_\_

Your ATD-5845 is warranted for a period of 12 months from the original purchase date.

For a period of one (1) year from your purchase date, ATD Tools Inc. will repair or replace (at its option) without charge, your ATD product if it was purchased new and the product has failed due to a defect in material or workmanship which you experienced during normal use of the product. This limited warranty is your exclusive remedy.

To access the benefits of this warranty, contact your supplier, or point of sale directly. You may be advised to return the product under warranty, freight prepaid, to your supplier for warranty determination.

If this ATD product is altered, abused, misused, modified, or undergoes service by an unauthorized technician, your warranty will be void. We are not responsible for damage to ornamental designs you place on this ATD product and such ornamentation should not cover any warnings or instructions or they may void the warranty. This warranty does not cover scratches, superficial dents, and other abrasions to the paint finish that occur under normal use. It also does not cover normal wear items such as but not limited to brushes, batteries, drill bits, drill chucks, pads or blades.

Subject to the law in your state:

- (1) Your sole and exclusive remedy is repair or replacement of the defective product as described above.
- (2) ATD is not liable for any incidental damages, including but not limited to, lost profits and unforeseeable consequences.
- (3) The repair and replacement of this product under the express limited warranty described above is your exclusive remedy and is provided in lieu of all other warranties, express or implied. All other warranties, including implied warranties and warranties of merchantability or fitness for a particular purpose are disclaimed and, if disclaimer is prohibited, these warranties are limited to one year from your date of purchase of this product.

Some states' laws do not allow limited durations on certain implied warranties and some states' laws do not allow limitations on incidental or consequential damages. You should consult the law in your state to determine how your rights may vary.

[Affix receipt or invoice here for safe keeping]