



## ATD-2025 25 Gallon Gas Caddy Owner's Manual



### Features:

- Works with gasoline, kerosene, diesel or mixed fuels
- Makes fuel transfer safe and easy
- Complies with OSHA guidelines
- Heavy-duty aluminum pump with DMC resin vanes
- Pump - two-way operation for either siphoning or dispensing
- Pump - 1 gallon for every 12 revolutions
- Fill level gauge
- Ground wire and clamp
- Fire-screened vent and filler neck combination
- Dolly handle for ease of movement

### Specifications:

- Pump Flow Volume: .8 - 4 gal/min (3-15L) 13.2 - 70.1 rpm
- Pump Lift: 196.85" (5m)
- Pump Sucking Height: 34.64" (880mm)
- Discharge Hose Length: 8' (2.45m)
- Caddy Capacity: 25 gallon
- Dimension: 24.80" x 20.86" x 47.24" (630 x 530 x 1200mm)
- Weight: 88 lbs.

# READ ALL INSTRUCTIONS BEFORE USING THIS PRODUCT

READ AND UNDERSTAND ALL SAFETY WARNINGS AND PRECAUTIONS CONTAINED IN THIS MANUAL.  
KEEP THIS INSTRUCTION MANUAL FOR FUTURE REFERENCE.



**NOTE:** The warnings and cautions discussed in this instruction manual cannot cover all possible conditions and situations that may occur. It must be understood by the operator that common sense and caution are factors which cannot be built into this product, but must be supplied by the operator.

## GENERAL SAFETY WARNINGS:

**WARNING:** The instructions and warnings contained in this manual should be read and understood before using or operating this tool. Do not allow anyone to use or operate this tool until they have read this manual and have developed a thorough understanding of how this tool works. Failure to observe any of the following instructions could result in severe personal injury to tool user and bystanders, or cause damage to the tool and property. Keep this manual for future reference.

**WARNING:** Use safety equipment. User and bystanders should use safety goggles or safety glasses with side shields which comply with current national standards. This applies to all persons in the work area.

**WARNING:** Keep bystanders and children out of the work area while operating this tool.

**WARNING:** Always keep your work area clean, uncluttered, and well lit. Cluttered or dark areas invite accidents and injuries. **DO NOT** work on floor surfaces that are slippery.

**WARNING:** Do not operate this tool if you are tired or under the influence of alcohol, drugs or medications that could affect your ability to use the tool properly.

**WARNING:** Dress properly. Do not wear loose clothing or jewelry as they can be caught in moving parts. Wear restrictive hair covering to contain long hair.

**WARNING:** Do not reach over or across running tools. Keep proper footing and balance at all times. Non-skid footwear is recommended when working.

## ATD-2025 SPECIFIC WARNINGS

**INSPECTION:** Check for worn, damaged, loose or missing parts before operating. An annual tank/component inspection is recommended.

**WARNING:** Failure to heed the following may result in personal injury and/or property damage.

- Carefully read and understand these instructions prior to using this equipment
- Always wear safety glasses when using this equipment
- Never operate this equipment on a vehicle with the engine running
- Operate this equipment only in a well ventilated area, and away from potential sources of flame or ignition
- Wear gloves and protective clothing to avoid the contact of gasoline on skin. If contact occurs, immediately wash the area and perform necessary first aid.
- Always keep a fire extinguisher on hand when performing fuel related service. Make sure the extinguisher is rated for fuel, electrical and chemical fires.
- Clean up fuel spills immediately after they occur.

## OWNER/OPERATOR RESPONSIBILITY

It is the owner's/operator's responsibility to:

- Properly use and maintain this equipment.
- Read and understand the instructions and warnings contained in this manual prior to operating this equipment.
- Have the contents of this manual explained in their native language if they do not understand any of the languages herein.
- Retain this manual for future reference to important warnings, operating and maintenance instructions.

Your ATD-2025 25 Gallon Gas Caddy is designed for safely transferring fuel to or from gas tanks prior to or following repair or removal. It utilizes a reversible manual rotary pump to draw fluid in or dispense fluid out of the 25 gallon storage tank, depending on the direction of rotation. Fuel may also be poured into the caddy through the filler tube. Simply remove the filler tube cap and direct the pour into the tube. Watch the sight level tube to prevent overfilling. Be sure not to fill the tank above the screen at the base of the filler tube.

## CARE AND MAINTENANCE

The fuel caddy does not require any particular maintenance other than normal cleaning. The unit should be cleaned using a cloth dampened with water, alcohol, or detergent recommended for household electrical appliances.

## ASSEMBLY

Refer to the exploded view and chart on page 3 for assistance with identifying parts and their location during assembly.

### Wheels (Figure 1) / Aluminum Foot Covers (Figure 2)

1. Insert the wheel shaft (#3) through the hole in the wheel brace welded to the tank.
2. Slide the spring washer (#2) onto the inside of the wheel shaft and screw the nut (#1) onto the shaft thread. Tighten hand tight.
3. Slide the flat washer (#29) and the snap ring (#28) over the wheel shaft and snap securely into slot in wheel shaft. Tighten nut on backside at this time. Repeat this procedure for the second wheel.
4. Slide aluminum foot cover (#27) over stabilizing bracket (B) aligning holes in both of them.
5. Secure with self plugging rivet (#26)

### Pump (Figure 3)

1. Apply PTFE tape to the thread on the pipe extending from the top of the tank (A).
2. Install the thread adapter (#33) and tighten it onto the pipe.
3. Install the pump (#13) by threading the inlet onto the thread adapter (#33).
4. Tighten the pump to the inlet pipe. NOTE: Be sure to orient the pump during final tightening, so the handle is easily accessible.
5. Slide the pump handle (#31) onto the pump shaft. Rotate the handle to align the set screw with the indentation on the shaft.
6. Tighten the set screw with hex wrench.

### Filler Pipe (Figure 4)

1. Apply PTFE tape to and thread the filler pipe (#9) into the screened port on top of the tank.
2. Install the cap (#10) onto the top of the filler pipe.



Figure 1



Figure 2



Figure 3



Figure 4

### Vent Cap / Gauge / Grounding Wire / Caddy Handle (Figures 5 - 8)

1. Apply PTFE tape to and thread the vent cap (#25) into the open port (w/o screen) located on top of the tank.
2. Apply PTFE tape to and thread the hex collar (#24) into the vent cap (#25). (Figure 5)
3. Insert the handle (#8) into the brackets (C) welded to the side of the tank and align the holes in the handle with those in the bracket.
4. Affix handle to welded brackets using screw, washer and nut (#6, #7 and #17) on both sides. (Figure 6)
5. Secure the ground wire eyelet (#14) onto one of the machine screws in the pump housing (#13). (Figure 7)
6. Apply PTFE tape to and thread brass fitting on the hose (#12) with PTFE tape and install it into the top of the pump (#13) and tighten with a wrench.



Figure 5



Figure 6

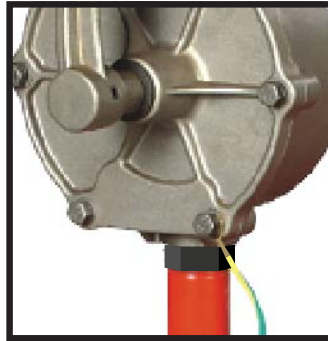

Figure 7



Figure 8

## OPERATION

### Set-up

1. Park the vehicle, turn off the ignition, and set the parking brake.
2. Disconnect vehicle's battery in accordance to the procedures outlined in your vehicle's owner's manual.
3. Ensure the caddy is properly positioned on level ground within required reach of the vehicle fuel tank.
4. Connect the ground wires extending from the pump and the tank handle to a known ground on the vehicle being serviced.

### Evacuating a Fuel Tank

1. Remove the cap from the car's fuel tank filler neck and attempt to feed the fluid transfer hose down the filler neck and into the fuel tank or raise the vehicle, disconnect the filler neck from the tank, and feed the hose directly into the tank.
2. Rotate the handle rapidly in a counterclockwise direction to prime the pump. Once primed, continue to rotate the pump handle at a comfortable rate to draw fuel from the tank into the caddy.

**CAUTION:** Pay attention to the sight level gauge on the top of the fuel caddy. **Do not overfill the tank.**

3. When transfer is complete, stop rotating the pump and allow excess fuel to drain from the hose.
4. Withdraw the hose from the tank and wrap it securely around the handle of the fuel caddy.
5. Disconnect the ground wires from the vehicle and wrap them securely around the fuel caddy handle.
6. Move the caddy to the next service job or proper storage area.

### Dispensing fuel from the Caddy

1. Remove the cap from the car's fuel tank filler neck and insert the fluid transfer hose securely into the neck opening.
2. Rotate the handle rapidly in a clockwise direction to prime the pump. Once primed, continue to rotate the pump handle at a comfortable rate to dispense fuel from the caddy into the tank.

**CAUTION:** Pay attention to level of fuel in the tank. **Do not allow it to overflow.**

3. When transfer is complete, stop rotating the pump and allow excess fuel to drain from the hose.
4. Withdraw the hose from the tank and wrap it securely around the handle of the fuel caddy.
5. Disconnect the ground wires from the vehicle and wrap them securely around the fuel caddy handle.
6. Move the caddy to the next service job or proper storage area.

## REPLACEMENT PARTS

Not all components of this product are replacement items, but are illustrated as a convenient reference for position in the assembly sequence. When ordering parts, give model number, part number and description. Call your distributor for current pricing:

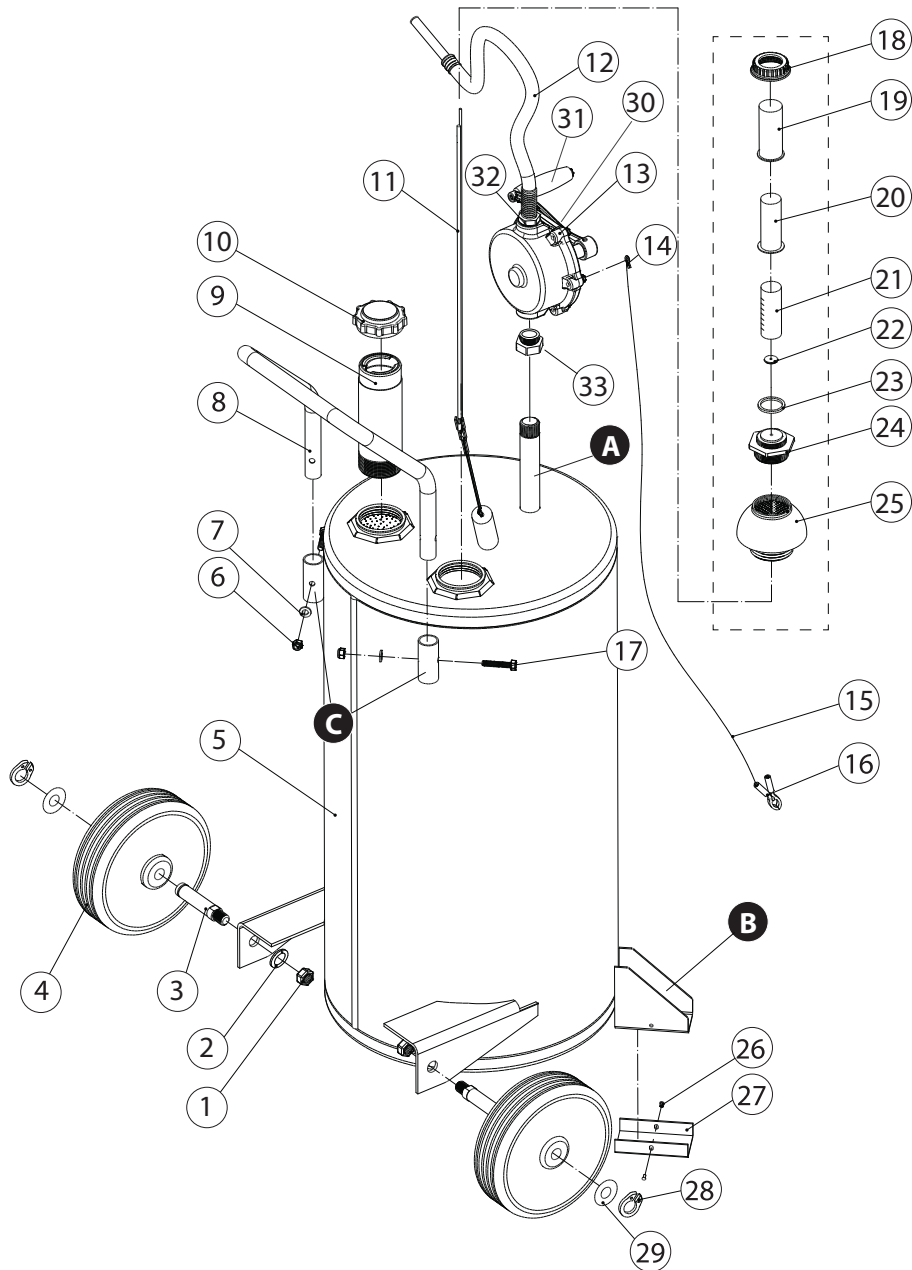

ITEM#	ORDERING PART#	PART DESCRIPTION
1	PRT2025-01	HEX NUT
2	PRT2025-02	SPRING WASHER
3	PRT2025-03	WHEEL SHAFT
4	PRT2025-04	WHEEL (8" x 1.75")
5	PRT2025-05	TANK
6	PRT2025-06	SCREW (M6)
7	PRT2025-07	FLAT WASHER
8	PRT2025-08	HANDLE
9	PRT2025-09	INLET TUBE
10	PRT2025-10	INLET CAP
11	PRT2025-11	OIL LEVEL FLOAT ASSEMBLY
12	PRT2025-12	DISCHARGE HOSE
13	PRT2025-13	PUMP ASSEMBLY
14	PRT2025-14-16	GROUND WIRE ASSEMBLY
15	PRT2025-14-16	GROUND WIRE ASSEMBLY
16	PRT2025-14-16	GROUND WIRE ASSEMBLY
17	PRT2025-17	HEX SCREW

ITEM#	ORDERING PART#	PART DESCRIPTION
18	PRT2025-18	FLOAT ASSEMBLY RETAINER
19	PRT2025-19	OUTSIDE GAUGE TUBE
20	PRT2025-20	INSIDE GAUGE TUBE
21	PRT2025-21	GAUGE
22	PRT2025-22	OIL LEVEL INDICATOR
23	PRT2025-23	O-RING (30 x 2.65)
24	PRT2025-24	HEX NUT
25	PRT2025-25	VENT CAP
26	PRT2025-26	SELF PLUGGING RIVET
27	PRT2025-27	ALUMINUM FOOT CAP
28	PRT2025-28	SNAP RING
29	PRT2025-29	FLAT WASHER
30	PRT2025-30	PUMP CRANK
31	PRT2025-31	PUMP CRANK HANDLE
32	PRT2025-32	BUSHING
33	PRT2025-33	THREAD ADAPTER



## WARRANTY

### 1 YEAR LIMITED WARRANTY

**THIS MANUAL, WARRANTY AND CONFIRMED RECEIPT(S) SHOULD BE RETAINED BY THE CUSTOMER AT ALL TIMES  
[Affix receipt or invoice here for safe keeping]**

PURCHASED FROM: \_\_\_\_\_

DATE PURCHASED: \_\_\_\_\_

INVOICE/RECEIPT NUMBER: \_\_\_\_\_

Your ATD-2025 is warranted for a period of 12 months from the original purchase date.

For a period of one (1) year from your purchase date, ATD Tools, Inc. will repair or replace (at its option) without charge, your ATD product if it was purchased new and the product has failed due to a defect in material or workmanship which you experienced during normal use of the product. This limited warranty is your exclusive remedy.

To access the benefits of this warranty, contact your supplier, or point of sale directly. You may be advised to return the product under warranty, freight prepaid, to your supplier for warranty determination.

If this ATD product is altered, abused, misused, modified, or undergoes service by an unauthorized technician, your warranty will be void. We are not responsible for damage to ornamental designs you place on this ATD product and such ornamentation should not cover any warnings or instructions or they may void the warranty. This warranty does not cover scratches, superficial dents, and other abrasions to the paint finish that occur under normal use. It also does not cover normal wear items such as but not limited to brushes, batteries, drill bits, drill chucks, pads or blades.

Subject to the law in your state:

- (1) Your sole and exclusive remedy is repair or replacement of the defective product as described above.
- (2) ATD is not liable for any incidental damages, including but not limited to, lost profits and unforeseeable consequences.
- (3) The repair and replacement of this product under the express limited warranty described above is your exclusive remedy and is provided in lieu of all other warranties, express or implied. All other warranties, including implied warranties and warranties of merchantability or fitness for a particular purpose are disclaimed and, if disclaimer is prohibited, these warranties are limited to one year from your date of purchase of this product.

Some states' laws do not allow limited durations on certain implied warranties and some states' laws do not allow limitations on incidental or consequential damages. You should consult the law in your state to determine how your rights may vary.

**DISPOSAL OF PACKAGING AND PRODUCT.** As the purchaser of this product you are responsible for disposing of the packaging in which it comes and for the product itself at end of use and must comply with all applicable environmental and/or other laws, rules, regulations and guidelines. If you transfer the product to any other person you must inform them of this responsibility. Consistent with EPR initiatives, most of our packaging and components are designated for resource recovery. These materials must be transferred to authorized facilities specializing in the processing and reclamation of industrial materials. In all circumstances, strict adherence to local environmental regulations is required to ensure proper material diversion.

