



**ATD-16900**

## **9-Piece HVLP Spray Gun Set Owner's Manual**



### **Features:**

- Produces high quality paint atomization
- High volume, low pressure minimizes overspray
- Fully adjustable wide fan pattern control

### **Set Includes:**

- (1) Touch-up Spray Gun
  - 1.0mm nozzle size
  - 125ml aluminum cup
- (1) Topcoat Spray Gun
  - 1.4mm nozzle size
  - 1000ml aluminum cup
- (1) Primer Spray Gun
  - 1.8mm nozzle size
  - 1000ml aluminum cup
- (1) Pressure Regulator (0-180 psi, 0-12 BAR)
- (1) Paint Gun Filter
- (1) Cleaning Kit:
  - (2) Spanner Wrenches
  - (1) Brush
  - (2) Filters

# INSTRUCTIONS

- Read this manual carefully and understand it completely.
- Retain manual for future use.
- **Always follow safety precautions to prevent personal injury and/or damage to the equipment.**
- Illustrations and photos are intended for reference only. Actual product may vary.
- Specifications are subject to change without notice.

## IMPORTANT SAFETY INSTRUCTIONS

1. Always wear eye protection, gloves and respirator to prevent against harmful vapors while spraying.
2. Never use oxygen or any other combustible or bottle gas as a propellant. Explosion and serious injury or death may result.
3. Many paints and solvents can be highly flammable. Please use the spray gun only in well-ventilated areas, do not smoke or use near open flame.
4. Always disconnect the paint gun from air supply when not in use and during maintenance.  
For emergency stopping and to prevent unintended operation, a valve near the gun is recommended.
5. Inspect the tool before each use to ensure there is no leakage or misaligned parts.  
Be sure the trigger moves freely.
6. Never use halogenated hydrocarbon solvent, as it can chemically react with aluminum and zinc parts of this tool.
7. Do not make any modifications to this tool.

Figure 1:

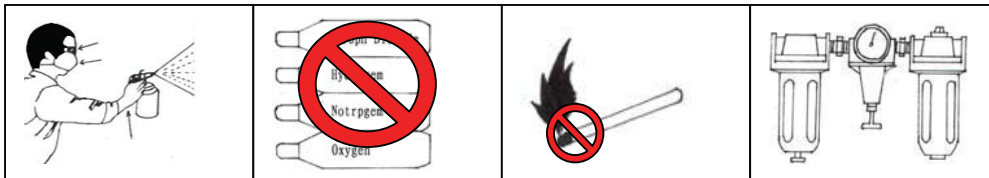

## OPERATING INSTRUCTIONS

### POWER SOURCE

This tool operates best on a clean, dry supply of compressed air delivered at 29 to 50 psi. Use of a moisture trapping air filter (ATD-7812) is highly recommended as moisture or foreign matter can damage the internal parts of this tool.

**CAUTION:** All air pressure in the system should be rated at 29 to 50 psi. Higher or lower pressure can adversely influence the operation or cause damage to this tool.

**NOTE:** To maintain 10 psi at the nozzle, use a minimum of 29 psi at the inlet.

## OPERATING INSTRUCTIONS CONTINUED

### TOOL PREPARATION

1. Check tool for worn or damaged parts. Repair or replace as necessary.
2. Check trigger to ensure that it moves freely.
3. Connect tool to air supply.
4. Adjust air pressure based on paint viscosity and paint manufacturers recommendation. (Figure 2)
5. Clean paint guns before use, to ensure any factory oils or pigments are not present.

**NOTE: DO NOT** use halogen hydrocarbon or acidic solvents to clean paint guns.

6. Pour paint into cup.

**Figure 2:**

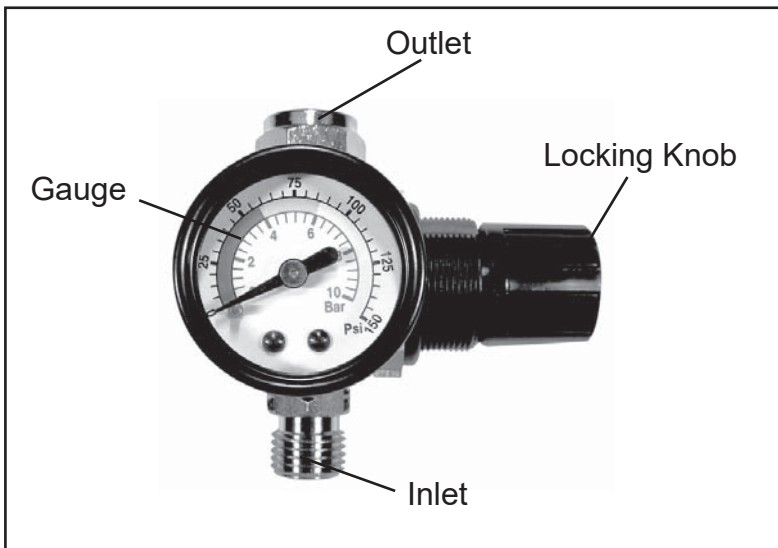

### Regulator Operation

- Pull locking knob to unlock
- Turn to set desired pressure
- Push to lock

### GUN HANDLING

For best results, please follow these basic guidelines:

1. Keep the spray gun perpendicular to the surface. Spraying in an arc will not give good results. (Figure 3)
2. Keep gun moving from one side to the other while spraying. If you stop moving the gun while you are spraying, too much paint will build up and begin to run. Begin the horizontal movement of the gun before you begin spraying. Also, keep the gun at a constant distance 6-12 inches from the surface. (Figure 4)

**Figure 3 – INCORRECT**

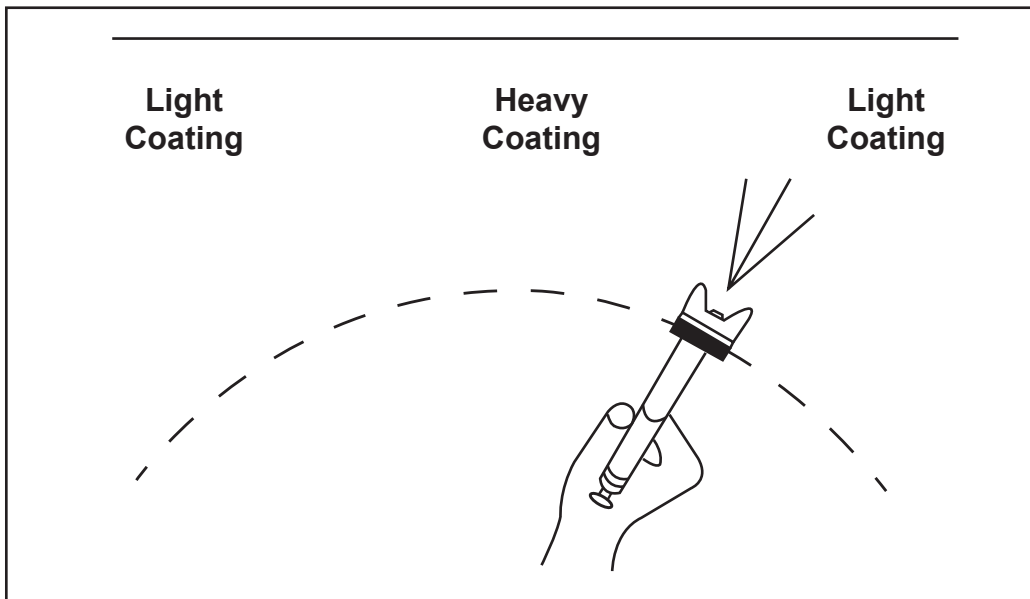

**Figure 4 – CORRECT**

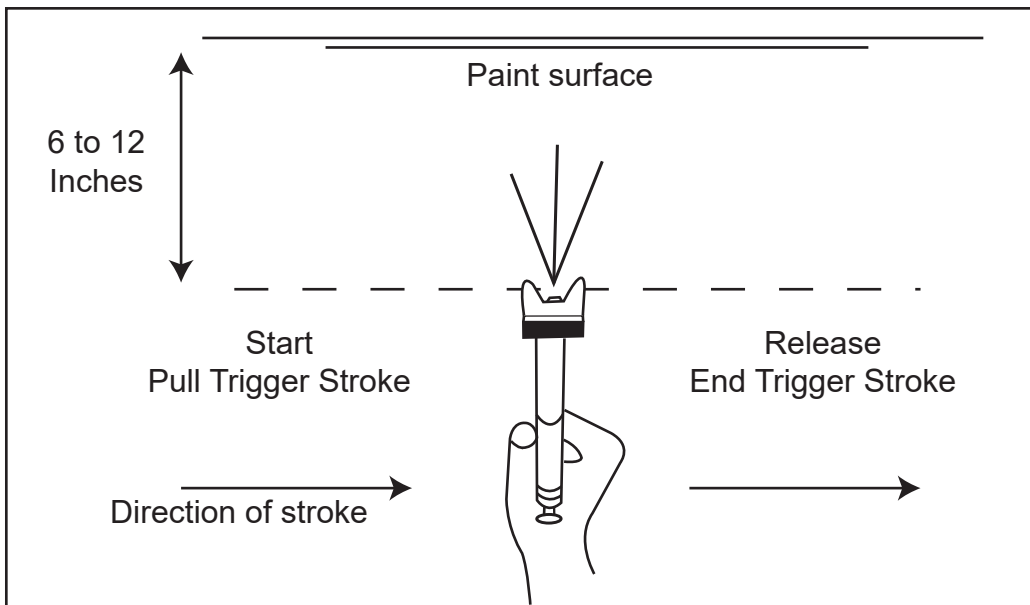

## ADJUSTMENT

1. Fine-tune the gun to your desired working settings of spray patterns, fluid output and degree of paint atomization using the three controls illustrated in Figure 5.

**Figure 5**

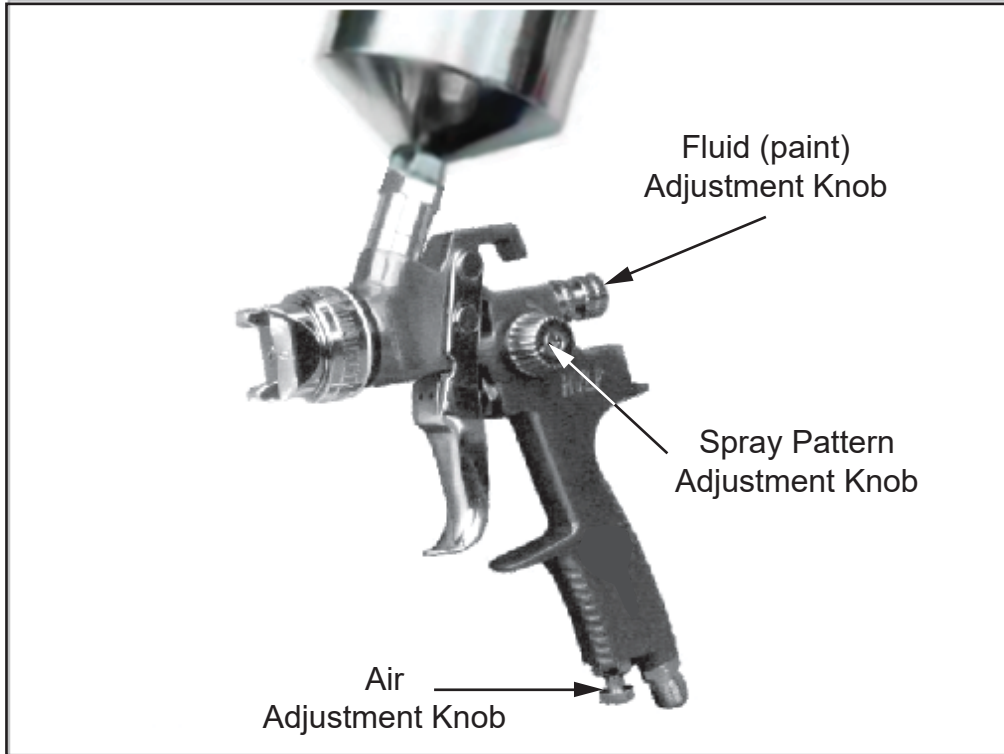

## MAINTENANCE

To clean the gun, pour any leftover paint back into its container. Using thinner, clean out the paint cup and cap. Spray some thinner through the gun to clean the spray head, needle and nozzle. Spray until thinner comes out clean. Clean all paint passages as any paint left in the gun and allowed to dry can clog the spray head.

Wipe the exterior of the gun with the cleaning brush included and a soft cloth moistened with thinner. If you remove the needle, remove the nozzle as well to protect the seat.

**NEVER DIG WITH A WIRE OR HARD OBJECT AS THIS CAN DAMAGE THE NEEDLE SEAT.**

Remove all such paint before it has a chance to dry.

## REPLACEMENT PARTS

Not all components of this product are replacement items, but are illustrated as a convenient reference for position in the assembly sequence. When ordering parts, give model number, part number and description. Call your distributor for current pricing:



**ATD-16903**  
1.0mm Gun  
(See drawing for parts)



**ATD-16902**  
1.8mm Gun  
(See drawing for parts)



**ATD-16901**  
1.4mm Gun  
(See drawing for parts)



**ATD-7812**  
Spray Gun Filter



**ATD-6926**  
Regulator



**PRT16900-TK**  
Tool Cleaning Kit





**ATD AIR**  
**ATD-16902**  
 1.8mm Gun

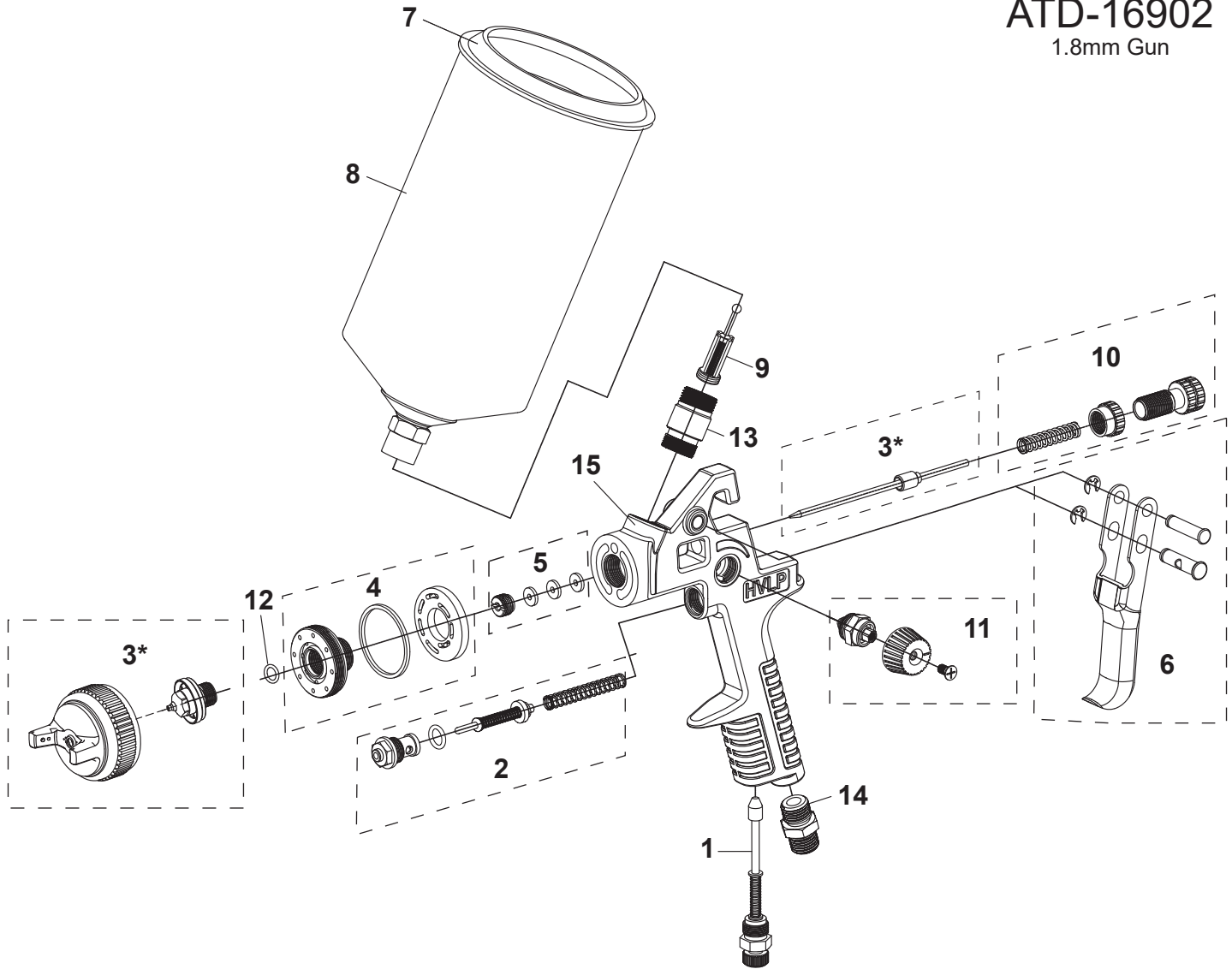

ITEM#	ORDERING PART#	PART DESCRIPTION
1	PRT16900-01	AIR ADJUST ASSY
2	PRT16900-02	AIR VALVE ASSEMBLY
3	PRT16900-1.8	1.8mm TIP KIT (NEEDLE, FLUID NOZZLE, AIR CAP)
4	PRT16900-04	FLUID NOZZLE ASSEMBLY
5	PRT16900-05	NEEDLE PACKING ASSEMBLY
6	PRT16900-06	TRIGGER ASSEMBLY
7	PRT16900-07	LID FOR CUP
8	PRT16900-08	CUP

ITEM#	ORDERING PART#	PART DESCRIPTION
9	PRT16900-09	FILTER (PACK OF 10)
10	PRT16900-10	FLUID ADJUST ASSEMBLY
11	PRT16900-11	PATTERN ADJUST ASSEMBLY
12	PRT16900-12	FLUID NOZZLE O-RING
13	PRT16900-13	PAINT CUP CONNECTOR
14	PRT16900-14	AIR INLET CONNECTOR
15	PRT16900-15	GUN BODY
N/A	PRT16900-RK	REPAIR KIT (ALL SEALS AND SPRINGS)*

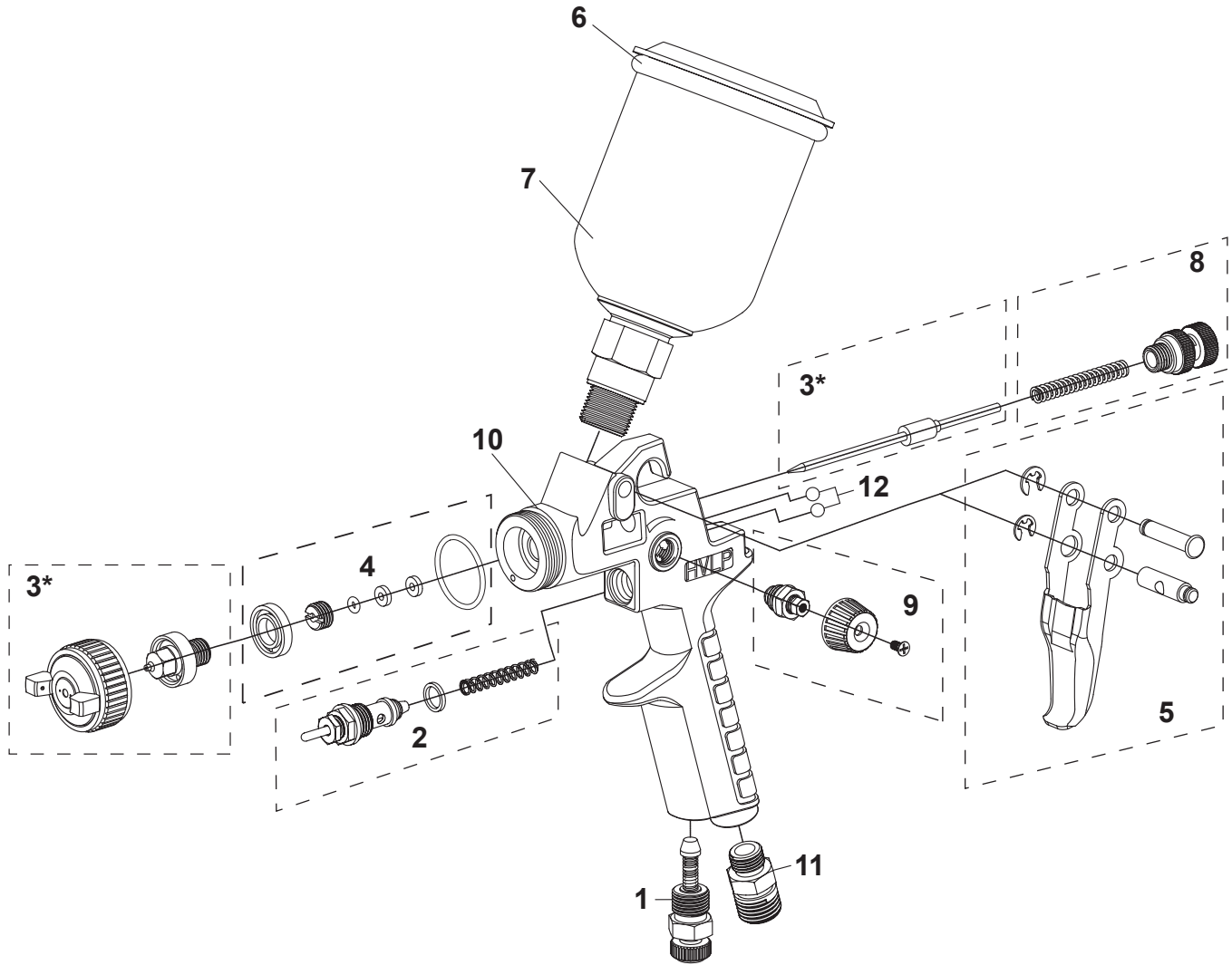

ITEM#	ORDERING PART#	PART DESCRIPTION
1	PRT16903-01	AIR ADJUST ASSEMBLY
2	PRT16903-02	AIR VALVE ASSEMBLY
3	PRT16903-1.0	1.0mm TIP KIT (NEEDLE, FLUID NOZZLE, AIR CAP)
4	PRT16903-04	NEEDLE PACKING ASSEMBLY
5	PRT16903-05	TRIGGER ASSEMBLY
6	PRT16903-06	LID FOR CUP
7	PRT16903-07	CUP

ITEM#	ORDERING PART#	PART DESCRIPTION
8	PRT16903-08	FLUID ADJUST ASSEMBLY
9	PRT16903-09	PATTERN ADJUST ASSEMBLY
10	PRT16903-10	GUN BODY
11	PRT16903-11	AIR INLET FITTING
12	PRT16903-12	STEEL BALL (x2)
N/A	PRT16903-RK	REPAIR KIT (ALL SEALS AND SPRINGS)



**ATD AIR**  
**WARRANTY**  
**1 YEAR LIMITED WARRANTY**

**THIS WARRANTY AND CONFIRMED RECEIPT(S) SHOULD BE RETAINED BY THE CUSTOMER AT ALL TIMES**

PURCHASED FROM: \_\_\_\_\_

DATE PURCHASED: \_\_\_\_\_

INVOICE/RECEIPT NUMBER: \_\_\_\_\_

Your ATD-16900 and its components are warranted for a period of 12 months from the original purchase date.

For a period of one (1) year from your purchase date, ATD Tools, Inc. will repair or replace (at its option) without charge, your ATD product if it was purchased new and the product has failed due to a defect in material or workmanship which you experienced during normal use of the product. This limited warranty is your exclusive remedy.

To access the benefits of this warranty, contact your supplier, or point of sale directly. You may be advised to return the product under warranty, freight prepaid, to your supplier for warranty determination.

If this ATD product is altered, abused, misused, modified, or undergoes service by an unauthorized technician, your warranty will be void. We are not responsible for damage to ornamental designs you place on this ATD product and such ornamentation should not cover any warnings or instructions or they may void the warranty. This warranty does not cover scratches, superficial dents, and other abrasions to the paint finish that occur under normal use. It also does not cover normal wear items such as but not limited to brushes, batteries, drill bits, drill chucks, pads or blades.

Subject to the law in your state:

- (1) Your sole and exclusive remedy is repair or replacement of the defective product as described above.
- (2) ATD is not liable for any incidental damages, including but not limited to, lost profits and unforeseeable consequences.
- (3) The repair and replacement of this product under the express limited warranty described above is your exclusive remedy and is provided in lieu of all other warranties, express or implied. All other warranties, including implied warranties and warranties of merchantability or fitness for a particular purpose are disclaimed and, if disclaimer is prohibited, these warranties are limited to one year from your date of purchase of this product.

Some states' laws do not allow limited durations on certain implied warranties and some states' laws do not allow limitations on incidental or consequential damages. You should consult the law in your state to determine how your rights may vary.

[Affix receipt or invoice here for safe keeping]