

ATD-80103

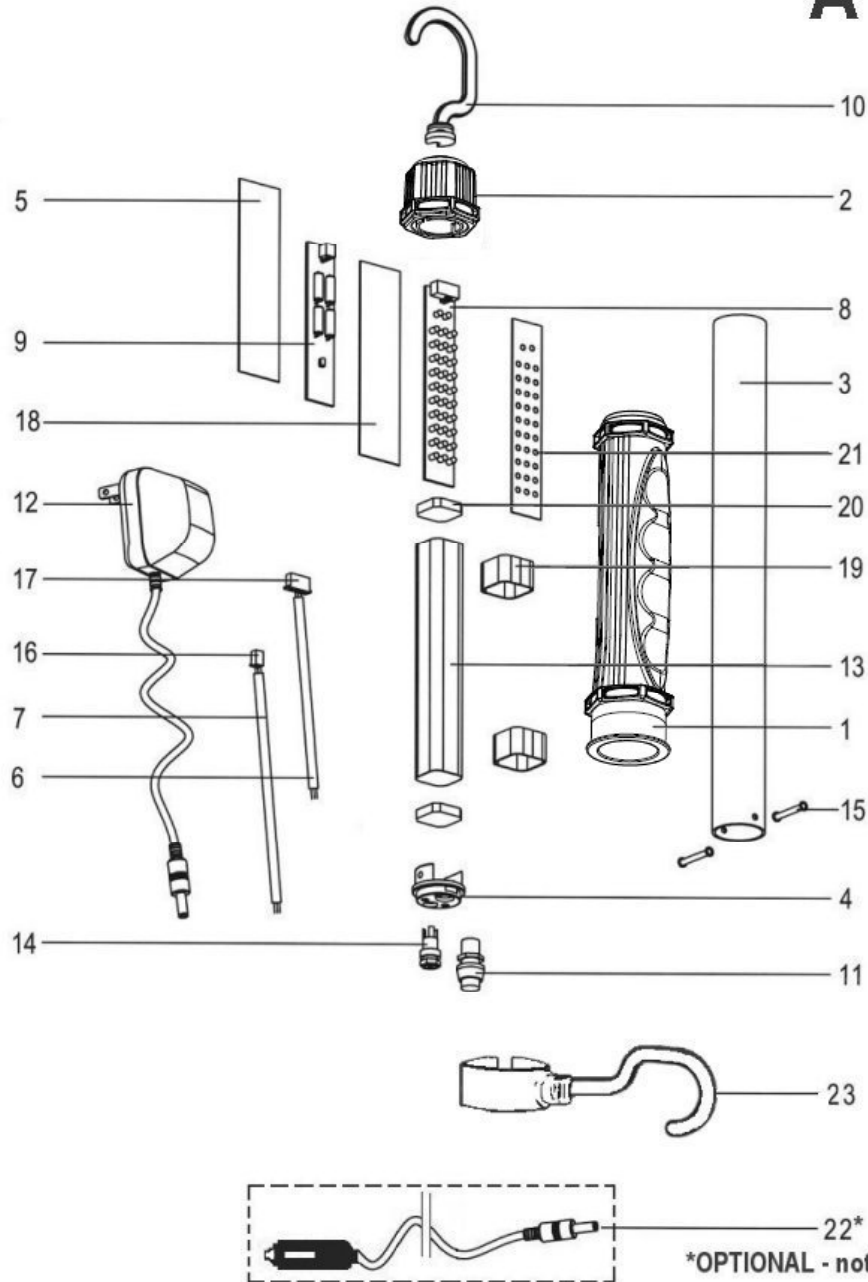

OPTIONAL - not included

ORDERING PART#	ITEM#	PART DESCRIPTION
PRT80103-01	1	HANDLE GRIP
PRT80103-02	2	TOP CAP
PRT80100-03	3	CLEAR TUBE
PRT80100-04	4	BASE
PRT80100-05	5	WHITE PAPER, 37.5X160XD.1MM
PRT80100-06	6	CONNECTION WIRE, BLACK
PRT80100-07	7	CONNECTION WIRE, RED
PRT80100-08	8	LED PCB
PRT80103-09	9	PCB
PRT80103-10	10	HOOK
PRT80100-11	11	KNOB SWITCH
PRT80100-12	12	ADAPTER, 120V 60HZ

ORDERING PART#	ITEM#	PART DESCRIPTION
PRT80100-13	13	BATTERY PACK, 14.4V 600MAH
PRT80100-14	14	FEMALE PLUG, ϕ 2.1 DS-025A
PRT80100-15	15	RIVET, 3.2X8
PRT80100-16	16	FEMALE CONNECTOR
PRT80100-17	17	FEMALE CONNECTOR
PRT80100-18	18	INSULATION BOARD
PRT80100-19	19	SHAKE-PROOF BAND, 75X15X1MM
PRT80100-20	20	SHAKE-PROOF BLOCK, 18X18X5MM
PRT80100-21	21	REFLECTIVE PAPER, 108X26MM
ATD80101	22	OPTIONAL DC CHARGING CORD
PRT80103-23	23	CLIP ON SWIVEL HOOK