



Model: ATD-702

**Non-contact infrared thermometer
Instruction manual**



INTRODUCTION

Compact, rugged and easy to use. Just aim and pull the trigger, read current surface temperatures in less than a second. Safely measure surface temperatures of hot, hazardous or hard-to-reach objects without contact.

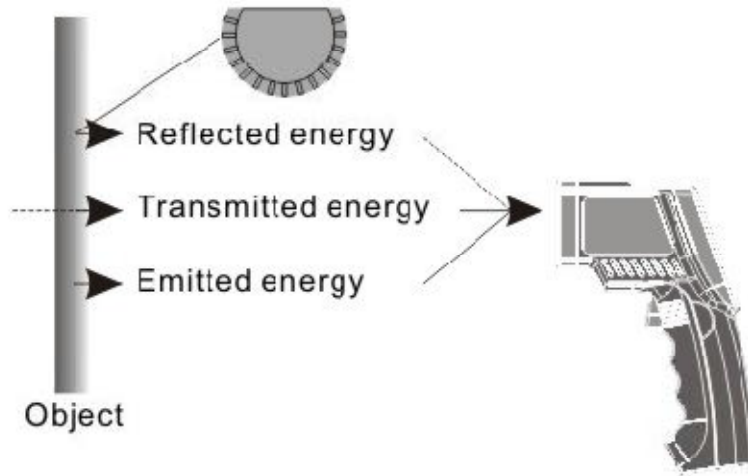

HOW IT WORKS

Infrared thermometer measures the surface temperature of an object. The unit's optics sense emitted, reflected, and transmitted energy which is collected and focused onto a detector. The unit's electronics translate the information into a temperature reading which is displayed on the LCD. For increased ease and accuracy the laser pointer makes aiming even more precise.

FUNCTIONS

- a. Laser indication
- b. Backlight
- c. High/Low temperature Alarm setup
- d. Max/Min/AVG and difference temperature functions
- e. Low battery indication
- f. Celsius / Fahrenheit selection
- g. Data store / recall function
- h. External K-TYPE thermocouple temperature measurement

SPECIFICATIONS

Temperature range	Infrared: -60~850°C (-76~1562°F); K-TYPE: -50°C~250°C(-58~482°F)
Accuracy	Infrared: -60°C~0°C(-76~32°F)± 3°C or± 3%; 0~250°C(32~482°F)± 2°C or± 2%; 250~850°C(482~1562°F)± 3°C or± 2% which ever is greater Test temperature: 23°C ± 2°C K-TYPE: -50~0°C(-58~32°F) ± (0.2%rgd+1°C); 0~99°C(32~210°F)± (0.2%rgd+1°C); 100~250°C(212~482°F)± (0.2%rgd+1°C)
Distance to spot size	12:1
Repeatability	1% of reading or ± 1°C
Response time	500ms
Spectral response	8~14 um
Emissivity	0.1~1.0 (pre-set 0.95)
Operating conditions	Temperature: 0~ 40°C Humidity: 10~90%RH noncondensing
Storage conditions	Temperature: -20~60°C Humidity: ≤ 85%RH, without battery
Low battery indication	7.2V± 0.2V
Power supply	9V Alkaline or NiCd battery
Battery life	Laser models: 12 hrs
Product size	175x100x49mm
Product weight	170g (without battery)

MAIN PARTS / FUNCTION DESCRIPTION

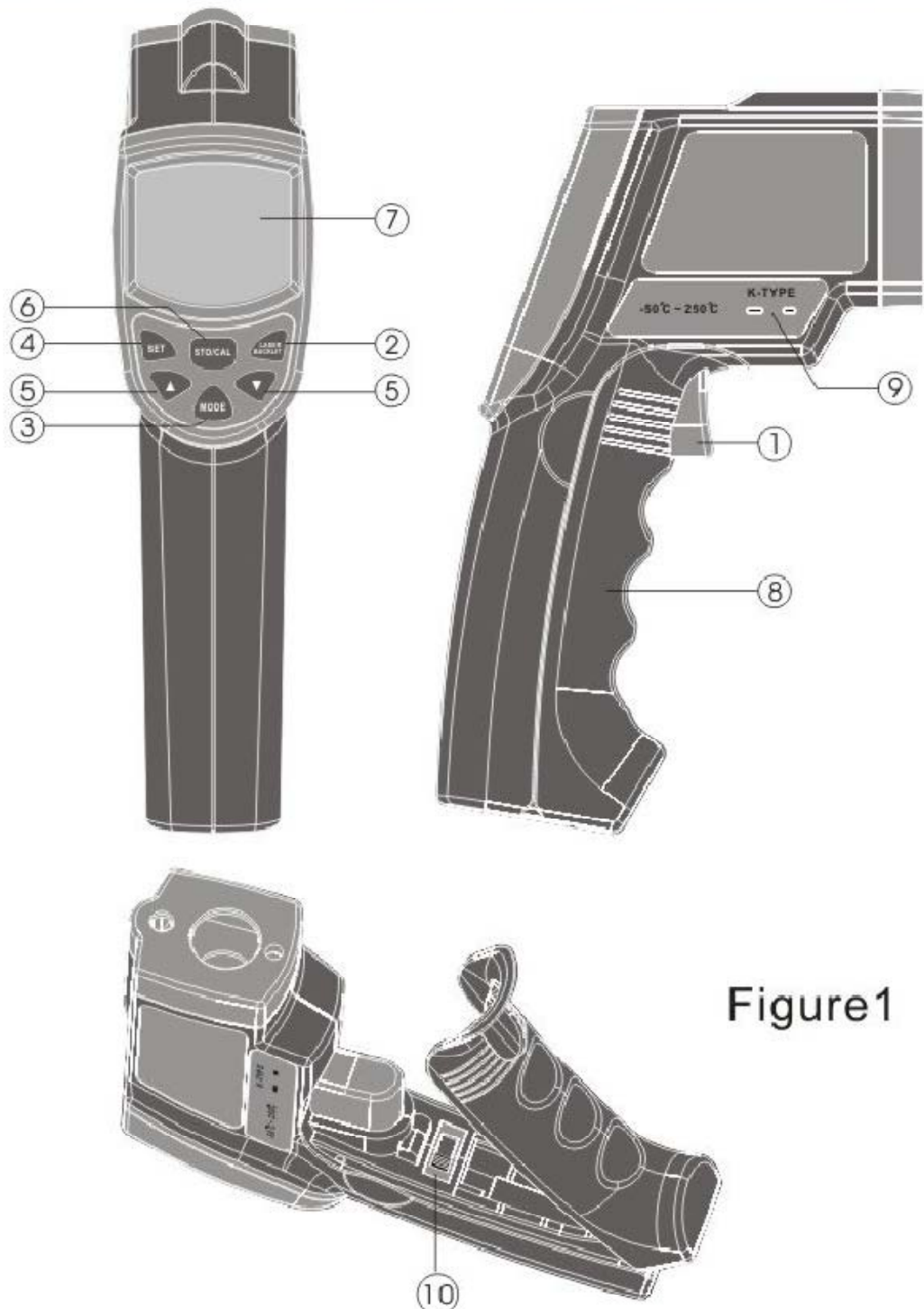

Figure1

- 1>.Measurement trigger
- 2>. Laser pointer and backlight key
- 3>. MODE: Mode switching key
- 4>. SET: Set ensuring key
- 5>. ▲ / ▼: Parameter selecting key
- 6>. STO/CAL: Data store / clear key
- 7>. LCD display

- 8>. Battery door
- 9>. K-TYPE thermocouple interface
- 10>. °C/°F switch

LCD DISPLAY



- A: Data hold icon
- B: Measurement reading
- C: Mode indicator
- D: Data store / read icon
- E: K-TYPE icon
- F: Low temperature alarm icon
- G: High temperature alarm icon
- H: Emissivity display
- I: Temperature unit: °C
- J: Temperature unit: °F
- K: Laser pointer ON icon
- L: Backlight ON icon
- M: Battery power indication icon
- N: Scanning icon

OPERATION

SWITCHING TEMPERATURE UNIT

Open the battery door, select your desired temperature ($^{\circ}\text{C}/^{\circ}\text{F}$) unit by pushing the slide switch, as shown in figure1.

MEASURING TEMPERATURE

Insert the 9V battery into the battery compartment, start the unit by pulling the trigger, the LCD will show the symbol 850 and VER for 1 second, aim the unit at the object surface to be measured, and pull the trigger to take measurement, When releasing the measuring trigger, the SCAN symbol will disappear, the HOLD symbol will appear and you will hear an audible tone (two quick, high beeps). The measured value will be held for 7 seconds automatically and the unit will auto power off after 30 seconds.

If there is no memory setting or all the settings have been cleared after power-on, the little numbers on the bottom of the LCD display will not be shown, if there is memory setting, the LCD will show a symbol DATA and last operating state of measurement.

MODE CONVERSION (Not for use with K-Type probe)

Press the MODE key, LCD sub-display blinks segment MAX-MIN-DIF-AVG-HAL-LAL-STO-EMS, (only main display mean normal measuring mode), press the SET to select function.

- a. MAX: measuring maximum temperature
- b. MIN: measuring minimum temperature
- c. DIF: Based on the reading before press SET key, calculates the difference of current reading.
- d. AVG: measuring average temperature



- e. HAL: high temperature alarm--When HAL is selected, press ▲/▼ keys to select desired high temperature and confirm by pressing SET key.
- f. LAL: low temperature alarm--When LAL is selected,, press ▲ /▼ keys to select desired low temperature and confirm by pressing SET key.
- g. STO: data storage
- H. EMS: Emissivity setup-- press ▲/▼ key for emissivity settings, press SET key to save set up and go back to normal status.

Most organic materials and painted or oxidized surfaces have an emissivity of 0.95 (pre-set in the unit). Inaccurate readings will result from measuring shiny or polished metal surfaces. To compensate for this, adjust the units emissivity reading (see table below) or cover the surface to be measured with masking tape or flat black paint. Measure the tape or painted surface when the tape or painted reach the same temperature as the material underneath. Table of approximate emissivity:

Marterial	Emissivity	Marterial	Emissivity
Aluminum	0.30	Iron	0.70
Asbestos	0.95	Lead	0.50
Asphalt	0.95	Limestone	0.98
Basalt	0.70	Oil	0.94
Brass	0.50	Paint	0.93
Brick	0.90	Paper	0.95
Carbon	0.85	Plastic	0.95
Ceramic	0.95	Rubber	0.95
Concrete	0.95	Sand	0.90
Copper	0.95	Skin	0.98
Dirt	0.94	Snow	0.90
Frozen food	0.90	Steel	0.80
Hot food	0.93	Textiles	0.94
Glass(plate)	0.85	Water	0.93
Ice	0.98	Wood	0.94

TEMPERATURE ALARM:

- 1>. HAL: When selected, measured temperature higher than the set HAL setting will result in a continuous audible alarm and **▶HIGH**) being displayed on the LCD readout.
- 2>. LAL: When selected, measured temperature lower than the set LAL setting will result in a continuous audible alarm and **▶LOW**) being displayed on the LCD readout.

Everytime the LASER/BACKLIGHT key is pressed, it will turn on or off one or both of the LASER/BACKLIGHT functions. The LASER symbol  or the BACKLIGHT symbol  or both will appear when that function is turned on.

Backlight : When backlight is turned on, every pull of the trigger will active the backlight for 10 seconds.

Laser : When Laser is turned on, every pull of the trigger will start the laser.

DATA STORAGE:

There are a total of 12 slots of memory open to store data. After taking a temperature reading, press the mode key until STO flashes, then press the set key once. It will automatically go to the next available storage slot. You will see a number followed by three dashes (1---) indicating which storage slot the measurement will be stored in. Press STO/CAL to store that data.

READING THE STORED DATA:

In normal measuring mode (EMS shown on readout) press the STO/CAL key to read stored data. Each press of the STO/CAL key will advance to the next stored data unit.





CLEARING THE STORED DATA:

When powered on, pressing the STO/CAL key for 4-5 seconds will clear all stored data. You cannot retrieve data once it has been cleared.

LOW BATTERY INDICATION:

The battery icon on the LCD readout will show you the state of charge on your battery. When the battery voltage is 7.2V($\pm 0.2V$) the icon will show the symbol:  indicating that you should replace the battery to prevent inaccurate measuring.

Battery icon shows 5 levels:

-  :battery is fully charged
-  :battery is sufficient
-  :battery is nearly deficient
-  :battery needs to be replaced
-  :battery is exhausted completely.

K-TYPE THERMOCOUPLE MEASUREMENT:

In measuring mode, after inserting the K-Type Thermocouple, the LCD will display the symbol K-Type with the temperature value of thermocouple, in this state the function conversion of Infrared temperature measurement: MAX-MIN-DIF-AVG-HAL-LAL-STO-EMS will not work.

If there are no measurements taken for 5 minutes after the K-Type inserted, the unit will auto power-off.

CAUTIONS

- 1>. Infrared thermometer should be protected from the following:
 - a. EMF (electro-magnetic fields) from arc welders, induction heaters.
 - b. Thermal shock (caused by large or abrupt ambient temperature changes. Allow 30 minutes for unit to stabilize before use).

- c. Do not leave the unit on or near objects of high temperature.

Warning:

Do not point laser directly at eye or indirectly into eye off reflective surfaces. As shown in figure 2:

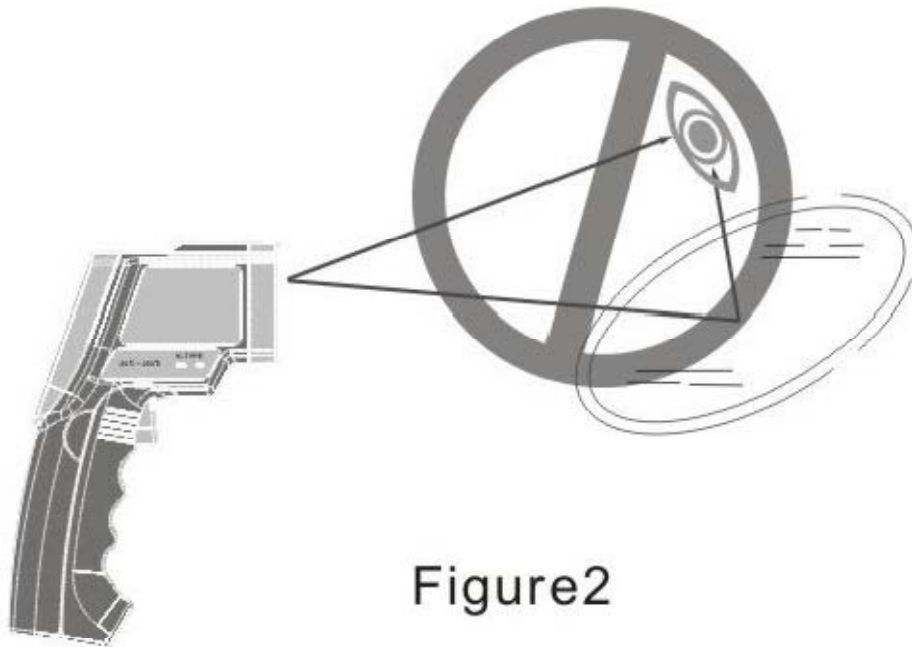

Figure2

- 2>. When take measurement, point thermometer toward the object to be measured and hold the trigger. The object under test should be larger than the spot size calculated by the field of view diagram.
- 3>. Distance & spot size: As the distance from the object increase, the spot size of measuring area becomes larger.

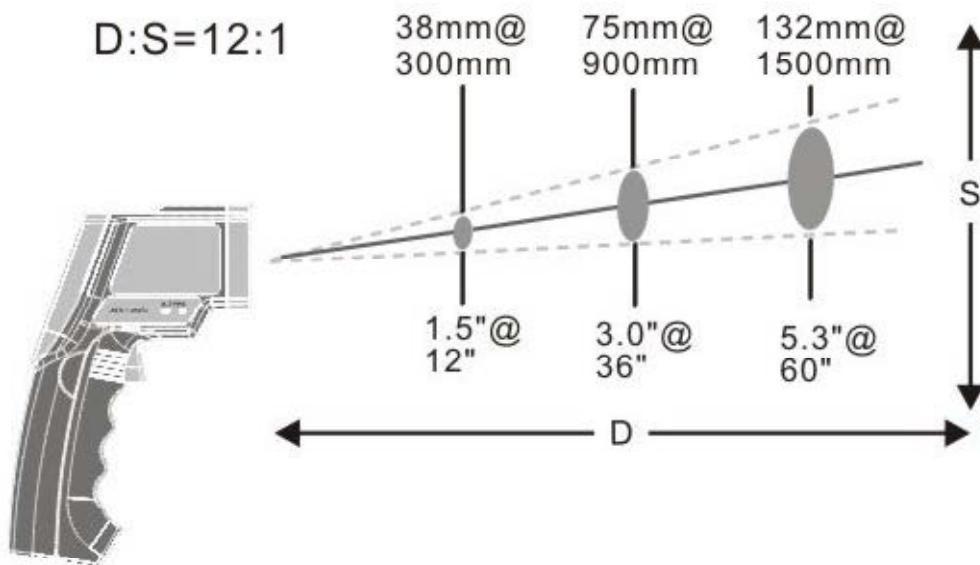

Figure3

4>. Field of view: Make sure the target is larger than the unit's spot size. The smaller the target the closer measure distance. When accuracy is critical, make sure the target is at least twice as large as the spot size.

5>. Locating a hot spot: To find a hot spot aim the thermometer outside the area of interest, then while still holding the trigger, scan across with up and down motions until you locate the hot spot. As shown in figure 4:

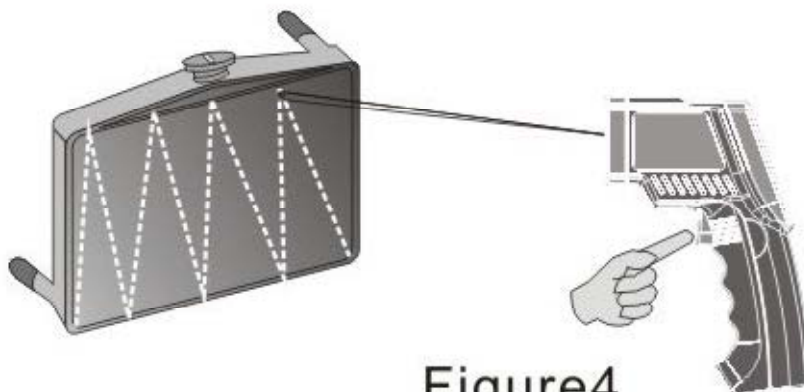

Figure4

MAINTENANCE

- 1>. Remove the battery from the unit if it is not required for extended periods of time in order to avoid damage to the unit resulting from a leaking battery.
- 2>. Do not store or use the unit where the unit may be subject to:
 - a. Splashes of water or high levels of dust.
 - b. Air with high salt or sulphur content or other gases.
 - c. High temperature or humidity or direct sunlight.
- 3>. Do not disassemble the unit or attempt internal alterations.
- 4>. Never use alcohol or thinner to clean the unit as they may melt and erode the plastic as well as the LCD readout. Clean the unit lightly as needed with a damp, clean cloth. Lens cleaning: Blow off loose particles using clean compressed air. Gently brush remaining debris away with a moist cotton cloth.

Warning: This product contains chemicals, including lead, known to the State of California to cause cancer, birth defects or other reproductive harm. Wash hands after handling.

